

Molteni & C

PANNA COTTA — RON GILAD 2012

1—
2



Panna Cotta low table oval or round. At once delicate and heavy, the paradox lies in the use of materials such as marble and iron to achieve a fragile stability. A small table, it has a slight wave on top reminiscent of the typical Italian soft dessert, from which it takes its name.

FEATURES

Thin structured table top in stabilised steel wire with a marble counterweight. The table top presents a slight vibration due to the elasticity of the structure.

DATASHEET

REGISTERED
DESIGN

IV.2016

molteni.it

Dimensions in millimeters and inches. The right to discontinue and make changes is reserved. This information is based on the latest product information available at the time of printing.

FINISHES

matt white lacquer with white Carrara marble
matt black lacquer with black marquina marble
matt red lacquer with red Laguna marble (only for small round tables)

Molteni & C

TECHNICAL INFORMATION

STRUCTURE

Welded drawn steel painted in the colours of the range. Nylon foot.

TOP

Steel sheet painted in the colours of the range.

COUNTERWEIGHT

Marble in the finishes of the range.

2—
2

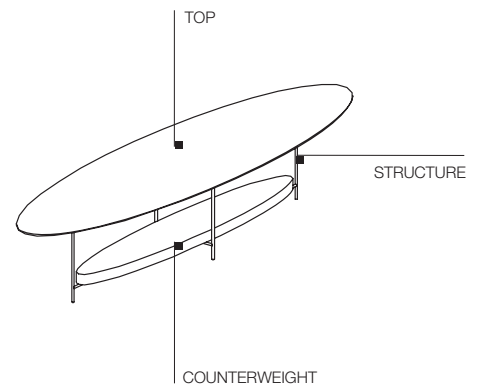
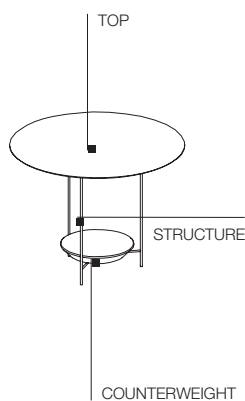
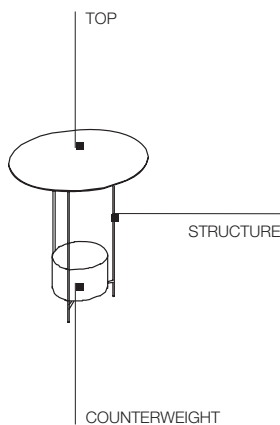

DIMENSIONS

small round table

Ø 400 H 500
Ø 15 3/4" H 19 5/8"



GPT1

small round table

Ø 550 H 420
Ø 21 5/8" H 16 1/2"



GPT3

oval small table

W 1800 D 500 H 350
W 70 7/8" D 19 5/8" H 13 3/4"

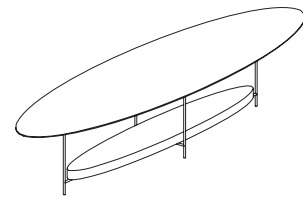

GPT2

DATASHEET

REGISTERED
DESIGN

IV.2016

molteni.it

Dimensions in millimeters and inches. The right to discontinue and make changes is reserved. This information is based on the latest product information available at the time of printing.

Molteni & C

FINISHES MOLTENI&C RANGE

IX.2016

WOODS

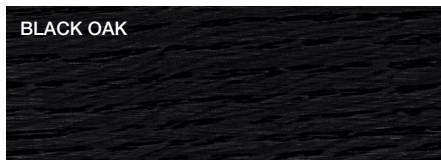
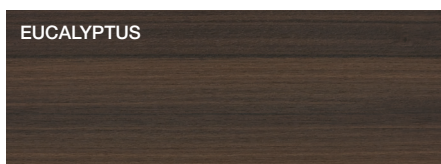

MARBLES

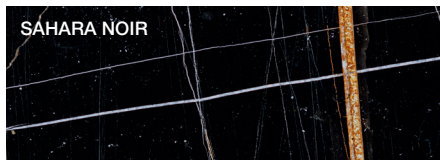
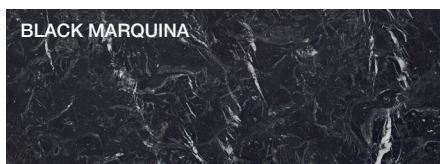
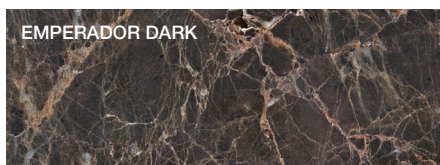
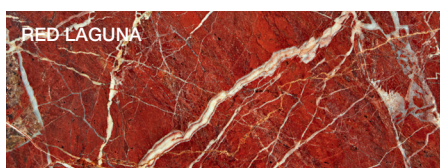
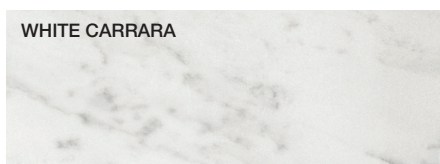

GRES

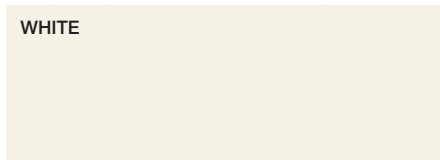

METAL PARTS

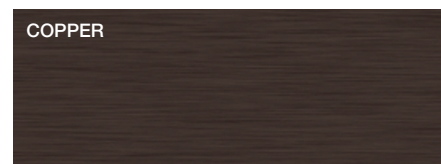
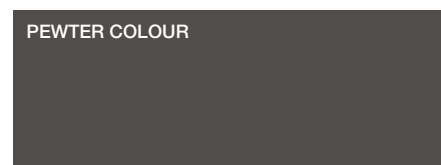
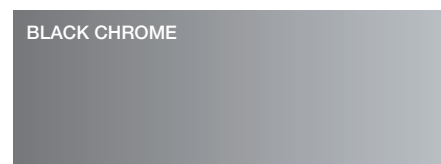

DWELL
DOOR FRAME, TRACK COVERING PROFILES

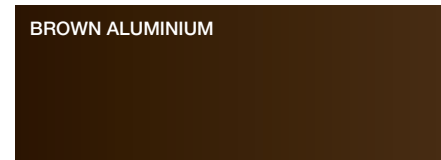

The finishes shown are indicative and refer to the entire production range. We recommend that you consult the "Colour Range" samples which shown the complete range of finishes, including those not shown here. Molteni&C reserves the right to modify the range without warning.