













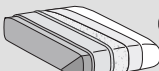

Blake high



	Seduta - Seat	Schienali - Backrests	Struttura - Structure	
Rivestimento Upholstering (12)	Sfoderabile Removable  			
	Non sfoderabile Not removable -			
Imbottiture Padding (4-5-6-7-8-9-10-11)	   D.35/50kg/m ³	  D.25/30kg/m ³	  Pol.espanso	 Optional

INFORMAZIONI TECNICHE

Struttura: 1-2

Masselli portanti in legno di abete e faggio di vari spessori. Fianchi di tamponamento in pannelli di legno multistrati e particelle di legno in classe E1, particolari in pannelli di fibra di legno dura o cellulosa.

Molleggio: 3

Schienale in nastri elastici di fibra propilenica e lattice meccanicamente pretensionati. Seduta in nastri elastici di fibra propilenica e lattice incrociati e meccanicamente pretensionati.

Note:

Articoli componibili abbinabili ad elementi del modello Blake low.

TECHNICAL INFORMATION

Structure: 1-2

Solid spruce and beech wood supports in various thicknesses. Buffer side in class E1 plywood and particleboard panels; details in hard or cellulose wood fibre panels.

Springing: 3

Backrest with pre-tensioned elastic strips in propylene fibre and latex. Seat with pre-tensioned crossed propylene fibre and latex elastic webbing.

Note:

Modular items combinable with Blake low elements.

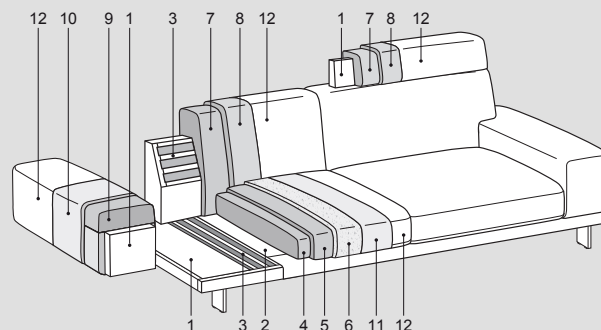
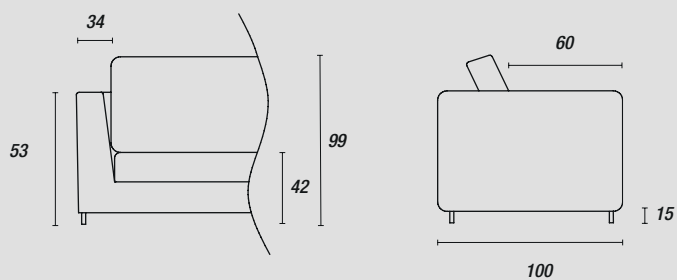

Piedini - Feet:

di serie Browse

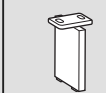

H.15cm

Nero (ME09)
Light brown (ME11)

optional Hulu



H.15cm

Nero (ME09)
Light brown (ME11)

Blake low



	Seduta - Seat	Schienali - Backrests	Struttura - Structure	
Rivestimento Upholstering (12)	Sfoderabile / Removable Icon: Fabric, Leather	Sfoderabile / Removable Icon: Fabric	Sfoderabile / Removable Icon: Fabric	
	Non sfoderabile / Not removable Icon: -	Non sfoderabile / Not removable Icon: Leather	Non sfoderabile / Not removable Icon: Leather	
Imbottiture Padding (4-5-6-7-8-9-10-11)	Icon: D.35/50kg/m³, memory foam	Icon: D.25/30kg/m³	Icon: Pol.espanso, Tecnoform	ECOSY ETHICALLY SOFT MADE Optional

INFORMAZIONI TECNICHE

Struttura: 1-2

Masselli portanti in legno di abete e faggio di vari spessori. Fianchi di tamponamento in pannelli di legno multistrati e particelle di legno in classe E1, particolari in pannelli di fibra di legno dura o cellulosa.

Molleggio: 3

Schienale in pannelli di fibra di legno dura o cellulosa.

Seduta in nastri elastici di fibra propilenica e lattice incrociati e meccanicamente pretensionati.

Note:

Articoli componibili abbinabili ad elementi del modello Blake high.

Tavolini in pannelli di particelle di legno in classe E1 impiallacciati. Accessorio per tavolino in metallo rivestito in rigenerato di cuoio.

TECHNICAL INFORMATION

Structure: 1-2

Solid spruce and beech wood supports in various thicknesses. Buffer side in class E1 plywood and particleboard panels; details in hard or cellulose wood fibre panels.

Springing: 3

The back is made of hard or cellulose wooden fibre panels.

Seat with pre-tensioned crossed propylene fibre and latex elastic webbing.

Note:

Modular items combinable with Blake high elements.

E1 particleboard panels veneered wooden small tables. Metal accessory for small table upholstered in recycled bonded leather.

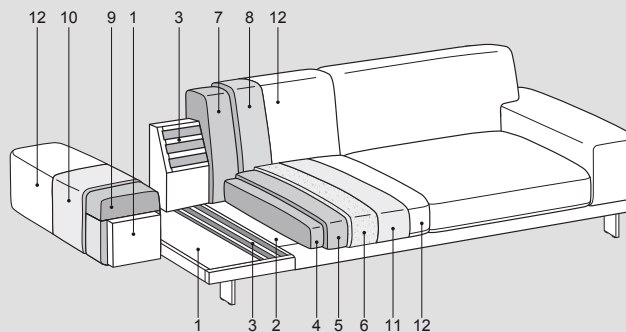
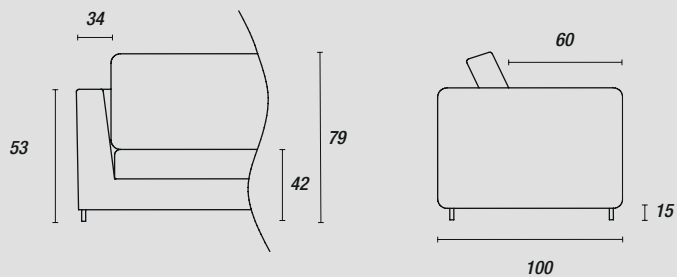

Piedini - Feet:

di serie Browse



Nero (ME09)
Light brown (ME11)

optional Hulu



Nero (ME09)
Light brown (ME11)

Accessori - Accessories:

Tavolino



Noce chocolate (LE16)
Grey wood (LE12)

Accessorio



Antracite (CR06)
Canapa (CR10)